

Clean Go Mobile Collectors

Light-Duty Portable Dust Collectors Fume Extractors

- X Ultra-Low Maintenance**
- X Plug-n-Go Operation**
- X Nominal 754 CFM**
- X 99.9% Filter Efficiency
Down to 0.5 Microns**
- X 360° Extraction Arm
for Precise Positioning**
- X Quiet 76 dBA Operation**
- X 1.5HP High Pressure
Motor Blower 120v**
- X 84 Square Feet Filter Area**



The **CLEAN GO** is the ideal solution for self-contained source capture of light-duty weld fume and other airborne contaminants in the workplace. This portable, compact dust and fume collector offers simple 120-volt plug-n-go convenience. The Clean Go is designed using the state-of-the-art technology in source capture and is a powerful, low-maintenance solution for even tough weld fumes.



Versatility, Convenience

Ideal for a wide variety of intermittent duty applications, the **Clean Go** captures hazardous fumes and dust at the source from spot welding, light grinding, deburring small batching and filing applications and much more.



The completely articulated, extendable extraction arm, capable of full 360° rotation, can be easily positioned to remove hazardous smoke and particulate before it contaminates the operator breathing zone.

Built to easily pass through standard doorways, the highly maneuverable **Clean Go** is ready to run with the flip of a switch.

- 99.9% Filter Efficiency

OPERATION

Weld fumes or other airborne contaminants are captured by the **Clean Go**, with incredible 764 CFM airflow, and are drawn into the unit and through the drop out chamber where the heavier particles separate from the air-stream. Lighter contaminants are then captured by two high-



**Toll Free (USA)
1-877-844-3293**

www.industrialairsolutions.com
infoez@industrialairsolutions.com

Clean Go

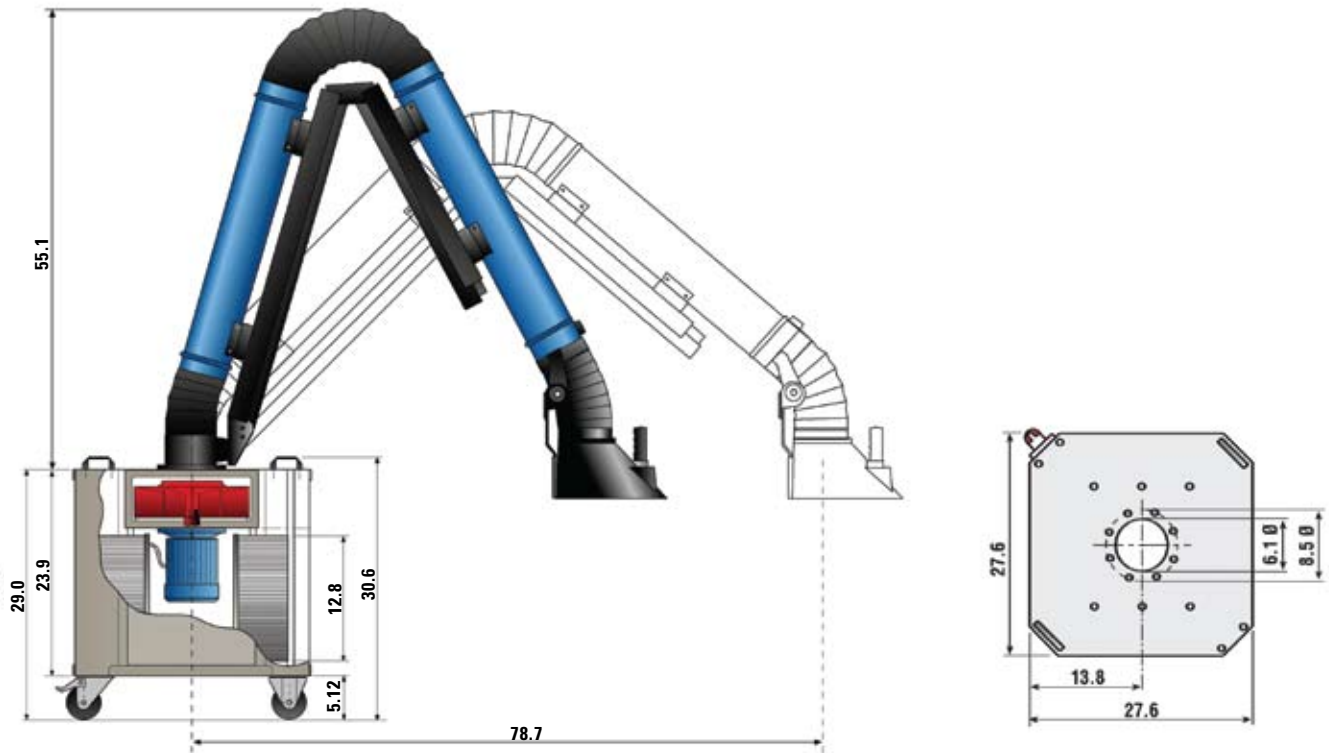

Working Area - 360° Arm Rotation

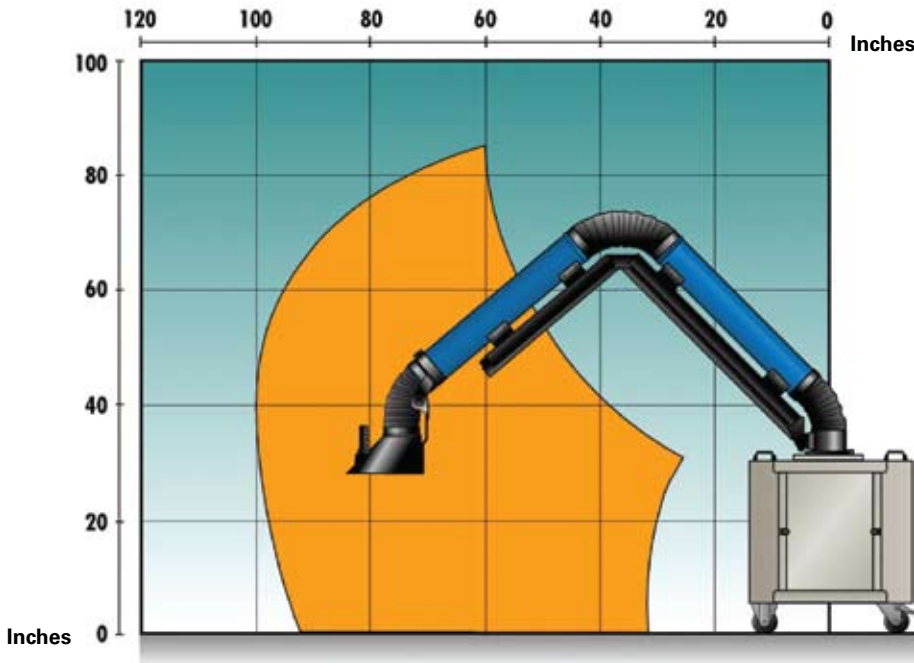

Clean Go	
Power	1.5 HP
Voltage	120V 60Hz 1PH 230/460V 60Hz 3PH
RPM	3400
Sound Level	76 dB (A)
Filtering area	84 Sq. ft.
Air flow at the hood with Charcoal filter	764 cfm
Air flow at the hood without Charcoal filter	823 cfm
Filtering efficiency	99.9%
Activated charcoal weight	5.5 Lb