

SPCBD-1000/2000

Backdraft Cartridge Fume Collectors

- X 1000/2000 Nominal CFM @5.5" Static Pressure
- X 115/220 Volt Single Phase 1.5 & 3 HP TEFC Motor
- X 8-Ft Cord & Plug (1000)
- X Direct Drive Forward Curved Blower
- X 177/295 Sq. Ft. Filter Area
- X 99% Efficiency @ .5µ
- X 80/20 Polyester Blend Flame Retardent HEPA-Like Cartridge Filter
- X Internal Baffle Protecting Cartridge Filter
- X Push Button Pulse Jet Filter Cleaning
- X Simple Tool-Free Filter Changeout
- X Mini-helic Filter Changeout Gauge
- X .9 Cubic Ft. Pullout Dust Collection Drawer
- X 11 & 14-Gauge Heavy-Duty Metal Construction
- X 10" Rear Wheels, 5" Front Swivel Wheels
- X Built-In Sound Attenuator
- X Bubble Access Seal on Blower & Filter Access Doors

Toll Free (USA)
1-877-844-3293

www.industrialairsolutions.com
infoez@industrialairsolutions.com

Industrial Air Solutions, Inc.
Fax: 919-518-1667
PO Box 90246
Raleigh, NC 27675

Go-Anywhere Portable Filtration

Industrial Air Solutions' SPCBD-1000/2000, portable cartridge backdraft fume and dust collectors are engineered for effective, economical control of dry dusts, fume, and smoke generated from sanding, polishing, buffing, grinding and other processes.

Ideal for light to moderate concentrations of dry contaminants, fumes, vapors, smoke and particulate are drawn down and back—away from the operator's breathing zone.

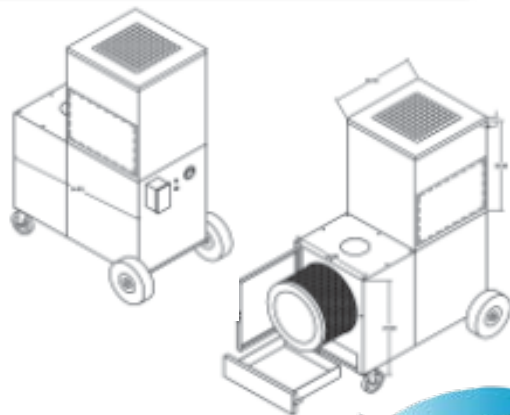

**Made Completely
in the USA!**



And these ultra-portable units are designed to go where you need them. Easily deployed on the shop floor and even transported in a standard utility van, the SPCBD-1000/2000 enable you to meet OSHA requirements without inhibiting productivity.

Low Maintenance Reliability

Highly efficient cartridge filters trap particulate down to .5 microns (with many filter options, including HEPA and carbon), while pulse-jet compressed air blasts keep filters clear and operating at optimum efficiency.

The SPCBD-1000 offers true plug-n-go convenience, with a power cord and switch,

SPCBD-1000/2000 Options

Exhaust-Side HEPA Module
for 99.97% Efficiency @ 0.3µ

Carbon & Other Filter Media Available

208-230/460 Volt Motor

Industrial Air
SOLUTIONS
inc.